

Micro i[®] Chip Inductors

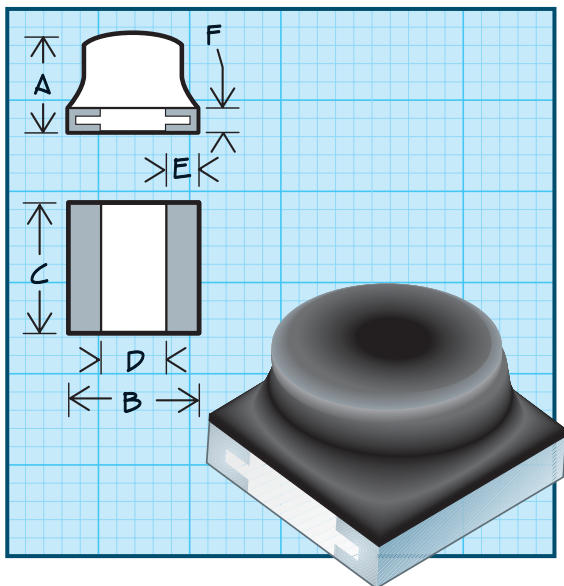

Military Specifications MIL-PRF-83446/4

Physical Parameters

	Inches	Millimeters
A	0.075 Max.	1.91 Max.
B	0.100 ± 0.010	2.54 ± 0.25
C	0.100 ± 0.010	2.54 ± 0.25
D	0.050 Min.	1.27 Min.
E	0.015 Min. (Typ.)	0.38 Min. (Typ.)
F	0.020 Max. (Typ.)	0.51 Max. (Typ.)

Weight Max. (Grams) 0.03

Current Rating at 90°C Ambient 35°C Rise

Operating Temperature Range -55°C to +125°C

Maximum Power Dissipation at 90°C 0.135 Watts

Termination Finish Options (Part # Code)

Gold over Nickel (Standard): As shown.

Tin/Lead over Nickel: Add suffix "S" to part # (e.g., 103-102KS).

Mil type "A:" Gold over Nickel (Standard)

Mil type "B" or "F:" Tin/Lead (solder) over Nickel.

RoHS type: Order 103R - XXXKS

Mechanical Configuration

Units are epoxy encapsulated.

Contact areas for reflow soldering are gold plated per MIL-G-45204 Type-1-Grade A. Internal connections are thermal compression bonded.

Packaging Tape & reel (8 mm): 7" reel, 2000 pieces max.; 13"-reel, 8000 pieces max.

Made in the U.S.A.

DASH NUMBER

MIL DASH #

INDUCTANCE (µH) see Note 3

TOLERANCE

Q MINIMUM

TEST FREQUENCY (MHz)

SRF MINIMUM (MHz)

DC RESISTANCE MAXIMUM (OHMS)

CURRENT RATING MAX. (mA)

M83446/4- SERIES 103 PHENOLIC CORE

-100(*)	30/37	0.010	± (**)	60	50.0	2700	0.060	1270
-120K	38	0.012	± 10%	57	50.0	2450	0.069	1190
-150(*)	31/39	0.015	± (**)	55	50.0	2200	0.078	1110
-180K	40	0.018	± 10%	52	50.0	2000	0.093	1030
-220(*)	32/41	0.022	± (**)	50	50.0	1800	0.108	950
-270K	42	0.027	± 10%	49	50.0	1625	0.114	925
-330(*)	33/43	0.033	± (**)	48	50.0	1450	0.120	900
-390K	44	0.039	± 10%	45	50.0	1335	0.133	860
-470(*)	34/45	0.047	± (**)	42	50.0	1220	0.145	820
-560K	46	0.056	± 10%	39	50.0	1110	0.170	760
-680(*)	35/47	0.068	± (**)	36	50.0	1000	0.195	705
-820K	48	0.082	± 10%	34	50.0	915	0.212	675
-101(*)	36/49	0.100	± (**)	32	50.0	830	0.230	650

M83446/4- SERIES 103 FERRITE CORE

-121K	1	0.12	± 10%	30	25.0	750	0.125	880
-151K	2	0.15	± 10%	25	25.0	650	0.175	745
-181K	3	0.18	± 10%	25	25.0	550	0.200	695
-221K	4	0.22	± 10%	25	25.0	450	0.220	665
-271K	5	0.27	± 10%	25	25.0	375	0.230	650
-331K	6	0.33	± 10%	25	25.0	300	0.235	645
-391K	7	0.39	± 10%	22	25.0	235	0.240	635
-471K	8	0.47	± 10%	22	25.0	215	0.260	610
-561K	9	0.56	± 10%	22	25.0	195	0.278	590
-681K	10	0.68	± 10%	22	25.0	175	0.520	435
-821K	11	0.82	± 10%	22	25.0	160	0.530	430
-102K	12	1.0	± 10%	22	25.0	145	0.540	425
-122K	13	1.2	± 10%	22	7.9	130	0.740	360
-152K	14	1.5	± 10%	22	7.9	115	0.840	340
-182K	15	1.8	± 10%	22	7.9	105	0.920	325
-222K	16	2.2	± 10%	22	7.9	85	1.00	310
-272K	17	2.7	± 10%	24	7.9	77	1.15	290
-332K	18	3.3	± 10%	24	7.9	70	1.40	260
-392K	19	3.9	± 10%	24	7.9	68	1.55	250
-472K	20	4.7	± 10%	24	7.9	60	1.80	230
-562K	21	5.6	± 10%	22	7.9	55	2.00	220
-682K	22	6.8	± 10%	22	7.9	50	2.20	210
-822K	23	8.2	± 10%	22	7.9	48	2.50	195
-103K	24	10.0	± 10%	24	7.9	40	3.45	165
-123K	25	12.0	± 10%	25	2.5	35	3.80	160
-153K	26	15.0	± 10%	25	2.5	30	5.60	135
-183K	27	18.0	± 10%	25	2.5	28	5.80	130
-223K	28	22.0	± 10%	25	2.5	25	6.40	125
-273K	29	27.0	± 10%	25	2.5	22	6.90	120

Parts listed above are QPL/MIL qualified

Optional Tolerances: J = 5% H = 3% G = 2% F = 1%

*Complete part # must include series # PLUS the dash #

For further surface finish information, refer to TECHNICAL section of this catalog.

Notes 1) Designed specifically for reflow soldering and other high temperature processes with metalized edges to exhibit solder fillet. 2) Self Resonant Frequency (SRF) Values above 250 MHz are calculated and for reference only. 3) (**) - MS slash numbers available in 20% (Suffix "M") and 10% (Suffix "K") tolerances.